

## 3. Moments and Pressure

*Remember to photocopy 4 pages onto 1 sheet by going A3→A4 and using back to back on the photocopier*

### Contents

Moments: ordinary level exam questions .....	2
Moments: higher level exam questions.....	3
Pressure: ordinary level exam questions .....	4
Boyle's Law.....	5
Solutions to ordinary level questions .....	6
Solutions to higher level questions.....	9

## Moments: ordinary level exam questions

### 2015 Question 12 (a) [Ordinary Level]

A bicycle can be steered by applying a pair of equal but opposite forces to the handlebars, which act as a lever.

- What is meant by the term *lever*?
- What is the name given to the turning effect of a force?
- What is the name given to a pair of equal but opposite forces?
- A cyclist's hands are placed 40 cm apart on the ends of the handlebars.  
To turn the bicycle, he applies a force of 20 N through each hand.  
Calculate the turning effect of the force.

### 2006 Question 12 (a) [Ordinary Level]

- Define the moment of a force.
- The diagram shows a crane in equilibrium.  
Give one condition that is necessary for the crane to be in equilibrium.
- What is the moment of the 9000 N concrete slab about the axis of the crane?
- Calculate the value of the load marked X.
- A crane is an example of a lever.  
Give another example of a lever.

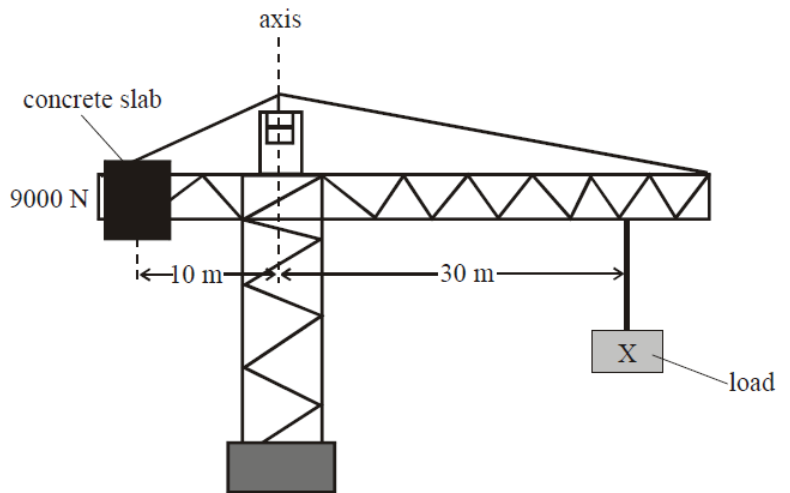

### 2003 Question 12 (a) [Ordinary Level]

- Define the moment of a force.
- Explain why the handle on a door is on the opposite side to the hinges of the door.
- A metre stick is suspended by a thread at the 20 cm mark as shown in the diagram. The weight  $W$  of the metre stick acts through the 50 cm mark. A weight of 2 N is placed at the 15 cm mark.  
(iv) Calculate the moment of the 2 N weight about the 20 cm mark.  
(v) What is the moment of  $W$  about the 20 cm mark?  
(vi) If the metre stick is in equilibrium, find the value of  $W$ .

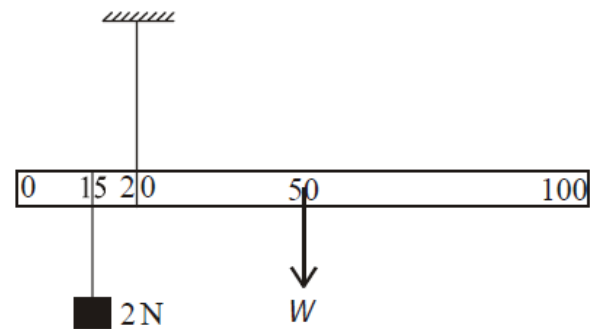

## Moments: higher level exam questions

### 2011 Question 6 (a) [Higher Level]

- (i) Define the moment of a force.
- (ii) A toy, such as that shown, has a heavy hemispherical base and its centre of gravity is located at C.
- When the toy is knocked over, it always returns to the upright position.
- Explain why this happens.



### 2011 Question 6 (b) [Higher Level]

- (i) State the conditions necessary for the equilibrium of a body under a set of co-planar forces.
- (ii) Three children position themselves on a uniform see-saw so that it is horizontal and in equilibrium. The fulcrum of the see-saw is at its centre of gravity.
- A child of mass 30 kg sits 1.8 m to the left of the fulcrum and another child of mass 40 kg sits 0.8 m to the right of the fulcrum.
- Where should the third child of mass 45 kg sit, in order to balance the see-saw?

### 2017 Question 12 (a) [Higher Level]

- (i) State the laws of equilibrium.

A sign weighing 400 N is suspended at the end of a uniform horizontal rod. The rod touches the wall at position X. The rod weighs 330 N and is 1.2 m long. A support cable makes an angle of  $35^\circ$  with the rod, as shown in the diagram.

- (ii) Calculate the clockwise moment acting on the rod (due to the weight of the sign and the weight of the rod) about X.
- (iii) Hence calculate the tension in the cable.

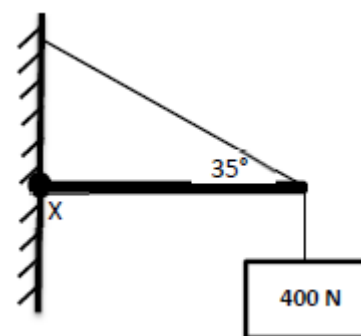

- (iv) A rotating object can be in equilibrium. Explain how this can happen.

## Pressure: ordinary level exam questions

### 2002 Question 12 (a) [Ordinary Level]

- (i) What is meant by pressure? Give the unit of pressure.
- (ii) Name an instrument used to measure pressure.
- (iii) When air is removed from the metal container shown in the diagram, it collapses. Explain why.
- (iv) The wind exerts a horizontal force of 1000 N on a wall of area 20 m<sup>2</sup>. Calculate the pressure at the wall.

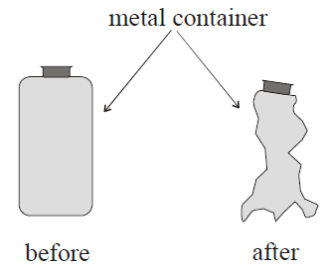

### 2005 Question 6 [Ordinary Level]

- (i) Define pressure and give the unit of pressure.
- (ii) Name an instrument used to measure pressure.
- (iii) The earth is covered with a layer of air called the atmosphere.  
What holds this layer of air close to the earth?
- (iv) Describe an experiment to show that the atmosphere exerts pressure.
- (v) The type of weather we get depends on the atmospheric pressure.  
Describe the kind of weather we get when the atmospheric pressure is high.
- (vi) The African elephant is the largest land animal.  
An elephant weighs 40 000 N and is standing on all four feet each of area 0.2 m<sup>2</sup>.  
Calculate the pressure exerted on the ground by the elephant.
- (vii) Why would the pressure on the ground be greater if the elephant stood up on just two feet?

### 2013 Question 12 (a) [Ordinary Level]

- (i) Define pressure.
- (ii) Describe an experiment to show that the atmosphere exerts pressure.
- (iii) A diver swims upwards from a depth of 50 m to a depth of 20 m below the surface of the water.  
Calculate the decrease in pressure on the diver as she swims upwards.  
(density of the water = 1000 kg m<sup>-3</sup>; g = 9.8 m s<sup>-2</sup>)



### 2009 Question 12 (a) [Ordinary Level]

- (i) Define pressure.
- (ii) Describe an experiment to show that the pressure in a liquid increases with depth.
- (iii) A diver is swimming in a lake at a depth of 5 m.  
He then dives deeper until he reached a depth of 30 m.  
Calculate the increase in pressure on the diver at this new depth.  
(density of water = 1000 kg m<sup>-3</sup>; g = 9.8 m s<sup>-2</sup>)



### 2014 Question 12 (b) [Ordinary Level]

- (i) State the unit of pressure.
- (ii) Describe an experiment to demonstrate that the atmosphere exerts pressure.
- (iii) State Archimedes' principle.
- (iv) The diagram shows the reading on a newton balance for an object suspended in air and in a liquid.  
The weight of the liquid displaced is also shown on a balance.  
What is the upthrust (buoyancy force) on the object caused by the liquid?
- (v) Will the object float in the liquid if released?
- (vi) Explain your answer.

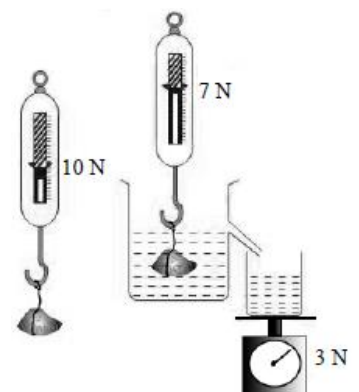

## Boyle's Law

### 2017 Question 12 (c) [Ordinary Level]

Mountain climbers encounter large changes in atmospheric pressure.

- (i) Define pressure and state its unit.
- (ii) Describe an experiment to demonstrate that the atmosphere exerts pressure.
- (iii) A weather balloon is released to test the weather at the height of Mount Everest, where atmospheric pressure is only  $3.0 \times 10^4$  Pa.  
The balloon has a volume of 2 litres when it is released from sea level.  
Calculate the volume of the balloon when it reaches the height of Mount Everest.  
(atmospheric pressure at sea level =  $10.1 \times 10^4$  Pa)

### 2011 Question 12 (a) [Ordinary Level]

- (i) State Boyle's law.
- (ii) Describe an experiment to demonstrate that the atmosphere exerts a pressure.
- (iii) Atmospheric pressure at the top of Mount Everest is very low at  $3.0 \times 10^4$  Pa, which is why climbers need oxygen tanks.  
A climber uses a 5.0 litre tank with an internal gas pressure of  $4.2 \times 10^6$  Pa to supply oxygen.  
What volume of gas will be available at the top of Mount Everest, when the gas is released from the tank?



### 2007 Question 12 (b) [Ordinary Level]

- (i) Define pressure.
- (ii) Describe an experiment to demonstrate that the atmosphere exerts pressure.
- (iii) State Boyle's law.
- (iv) A balloon rises through the atmosphere while the temperature remains constant.  
The volume of the balloon is  $2 \text{ m}^3$  at ground level where the pressure is 1000 hPa.  
Find the volume of the balloon when it has risen to a height where the atmospheric pressure is 500 hPa.
- (v) What will happen to the balloon as it continues to rise?

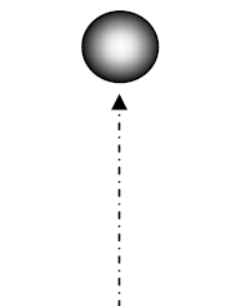

### 2006 Question 12 (a) [Higher Level]

- (i) Define pressure.
- (ii) Is pressure a vector quantity or a scalar quantity? Justify your answer.
- (iii) State Boyle's law.
- (iv) A small bubble of gas rises from the bottom of a lake. The volume of the bubble increases threefold when it reaches the surface of the lake where the atmospheric pressure is  $1.01 \times 10^5$  Pa.  
The temperature of the lake is  $4^\circ\text{C}$ . Calculate the pressure at the bottom of the lake;
- (v) Calculate the depth of the lake.  
(acceleration due to gravity =  $9.8 \text{ m s}^{-2}$ ; density of water =  $1.0 \times 10^3 \text{ kg m}^{-3}$ )

## Solutions to ordinary level questions

### 2017 Question 12 (c)

(i) **Define pressure and state its unit.**

force per unit area

(ii) **Describe an experiment to demonstrate that the atmosphere exerts pressure.**

*apparatus:* e.g. can of water and heat source

*procedure:* e.g. boil water and put on lid

*observation:* e.g. can collapses

accept valid alternatives

(iii) **Calculate the volume of the balloon when it reaches the height of Mount Everest.**

$$P_1V_1 = P_2V_2 \quad \Rightarrow (10.1 \times 10^4)(2) = (3.0 \times 10^4)(V_2) \quad \Rightarrow V_2 = \frac{20.2 \times 10^4}{3.0 \times 10^4} = 6.7 \text{ L.}$$

### 2015 Question 12 (a)

(i) **What is meant by the term *lever*?**

A rigid body which is free to rotate

(ii) **What is the name given to the turning effect of a force?**

Moment//torque

(iii) **What is the name given to a pair of equal but opposite forces?**

A couple

(iv) **Calculate the turning effect of the force.**

$$\text{Moment of a couple} = \text{force} \times \text{distance} = 20 \times 0.4 \quad \text{Moment} = 8 \text{ N m}$$

### 2014 Question 12 (b)

(i) **State the unit of pressure.**

Pa / N m<sup>-2</sup>

(ii) **Describe an experiment to demonstrate that the atmosphere exerts pressure.**

*apparatus:* glass of water and cardboard // can of water and heat source

*procedure:* place cardboard over glass and invert // boil water and put on lid

*observation/conclusion:* water remains in glass // can collapses

(iii) **State Archimedes' principle.**

The upthrust (on a body immersed in a liquid) is equal to the weight of the liquid displaced.

(iv) **What is the upthrust (buoyancy force) on the object caused by the liquid?**

3 N

(v) **Will the object float in the liquid if released?**

No

(vi) **Explain your answer.**

the upthrust is less than the weight/ it is more dense

### 2013 no.12 (a)

(i) **Define pressure.**

Pressure = Force ÷ Area

(ii) **Describe an experiment to show that the atmosphere exerts pressure.**

*apparatus:* can (containing water) // can (of air) // glass of water

*procedure:* boil water in can // pump // cardboard / lid seal / invert in cold water // air out // invert

*observation/conclusion:* can crushes / collapses

(iii) **Calculate the decrease in pressure on the diver as she swims upwards.**

$$\Delta P = \rho g(\Delta h) = (1000)(9.8)(30) = 2.94 \times 10^5 \text{ Pa}$$

### 2011 Question 12 (a)

(i) **State Boyle's law.**

For a fixed mass of gas kept at a constant temperature the pressure is inversely proportional to the volume

(ii) **Describe an experiment to demonstrate that the atmosphere exerts a pressure.**

*apparatus:* can (containing water) // can (of air) // glass of water

*procedure:* boil water in can // pump // cardboard / lid

seal / invert in cold water // air out // invert

*observation/conclusion:* can crushes / collapses // lid supported

(iii) **What volume of gas will be available at the top of Mount Everest, when the gas is released from the tank?**

$$P_1V_1 = P_2V_2$$

$$(4.2 \times 10^6)(5) = (3.0 \times 10^4)(V_2)$$

$$V = 700 \text{ litres}$$

### 2009 Question 12 (a)

(i) **Define pressure.**

Pressure is defined as force/area.

(ii) **Describe an experiment to show that the pressure in a liquid increases with depth.**

Set up as shown.

Note that the water coming out of the hole at the bottom travels the farthest because it is under the greatest pressure.

(iii) **Calculate the increase in pressure on the diver at this new depth**

$$\Delta P = \rho g(\Delta h) = (1000)(9.8)(25) = 2.45 \times 10^5 \text{ Pa}$$

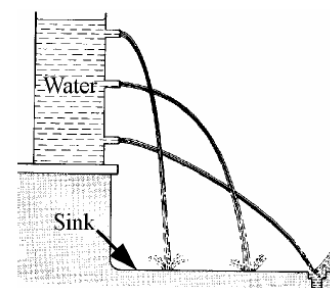

### 2007 Question 12 (b)

(i) **Define pressure.**

Pressure = Force divided by Area.

(ii) **Describe an experiment to demonstrate that the atmosphere exerts pressure.**

*Apparatus:* glass of water and cardboard

*Procedure:* place cardboard over glass and invert

*Observation/conclusion:* water remains in glass

(iii) **State Boyle's law.**

Boyle's Law states that at constant temperature, the volume of a fixed mass of gas is inversely proportional to its pressure.

(iv) **Find the volume of the balloon when it has risen to a height where the atmospheric pressure is 500 hPa.**

$$P_1V_1 = P_2V_2 \Rightarrow 1000 \times 2 = 500 \times V_2 \Rightarrow V_2 = (1000 \times 2)/500 = 4 \text{ m}^3.$$

(v) **What will happen to the balloon as it continues to rise?**

It will continue to expand

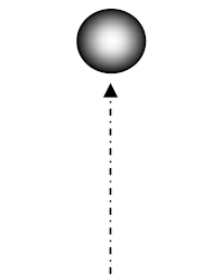

### 2006 Question 12 (a)

(i) **Define the moment of a force.**

The moment of a force is equal to the force multiplied by the distance between the force and the fulcrum.

(ii) **Give one condition that is necessary for the crane to be in equilibrium.**

The clockwise moments must equal the anticlockwise moments.

(iii) **What is the moment of the 9000 N concrete slab about the axis of the crane?**

$$\text{Moment} = F \times \text{distance} = 9000 \times 10 = 90000 \text{ N m.}$$

(iv) **Calculate the value of the load marked X.**

$$9000 \times 10 = 30x \Rightarrow x = 3000 \text{ N.}$$

(v) **A crane is an example of a lever. Give another example of a lever.**

Crowbar / nailbar / nutcracker / wheelbarrow / tongs / door handle etc.

### 2005 Question 6

- (i) **Define pressure and give the unit of pressure.**

Pressure = force ÷ area. The unit of pressure is the pascal.

- (ii) **Name an instrument used to measure pressure.**

The barometer.

- (iii) **The earth is covered with a layer of air called the atmosphere. What holds this layer of air close to the earth?**

Gravity.

- (iv) **Describe an experiment to show that the atmosphere exerts pressure.**

Apparatus: glass of water and cardboard

Procedure: place cardboard over glass and invert

Observation/conclusion: water remains in glass

- (v) **Describe the kind of weather we get when the atmospheric pressure is high.**

Good weather, dry, clear skies, little wind, settled.

- (vi) **Calculate the pressure exerted on the ground by the elephant.**

$$P = F/A \Rightarrow P = 40\,000/0.8 \Rightarrow P = 5,000 \text{ Pa.}$$

- (vii) **Why would the pressure on the ground be greater if the elephant stood up on just two feet?**

The area would be smaller.

### 2003 Question 12 (a)

- (i) **Define the moment of a force.**

The moment of a force = the force × perpendicular distance between the force and the fulcrum.

- (ii) **Explain why the handle on a door is on the opposite side to the hinges of the door.**

In order to maximise the distance between the force and the fulcrum.

- (iii) **A metre stick is suspended by a thread at the 20 cm mark as shown in the diagram. The weight  $W$  of the metre stick acts through the 50 cm mark. A weight of 2 N is placed at the 15 cm mark. Calculate the moment of the 2 N weight about the 20 cm mark.**

$$M = F \times d = 2 \times 0.05 = 0.1 \text{ N m.}$$

- (iv) **What is the moment of  $W$  about the 20 cm mark?**

$$M = F \times d = 0.3 W \text{ N m}$$

- (v) **If the metre stick is in equilibrium, find the value of  $W$ .**

$$0.1 = 0.3W \Rightarrow W = 0.33 \text{ N}$$

### 2002 Question 12 (a)

- (i) **What is meant by pressure? Give the unit of pressure.**

Pressure is force divided by area. The unit of pressure is the pascal.

- (ii) **Name an instrument used to measure pressure.**

The barometer.

- (iii) **When air is removed from the metal container shown in the diagram, it collapses. Explain why.**

The pressure outside (due to atmospheric pressure) is greater than the pressure inside.

- (iv) **The wind exerts a horizontal force of 1000 N on a wall of area 20 m<sup>2</sup>. Calculate the pressure at the wall.**

$$P = F/A = 1000/20 = 50 \text{ Pascals.}$$



## Solutions to higher level questions

### 2017 Question 12 (a)

(v) **State the laws of equilibrium.**

1. The vector sum of the forces in any direction is zero
2. The sum of the moments about any point is zero

(vi) **Calculate the clockwise moment acting on the rod (due to the weight of the sign and the weight of the rod) about X.**

There are 2 forces here; the weight of the sign and the weight of the rod (acting through the centre of gravity of the rod)

$$\text{Moment of force} = (400)(1.2) + (330)(0.6) = 678 \text{ N m}$$

(vii) **Hence calculate the tension in the cable.**

Total clockwise moment = anti-clockwise moment

Anti-clockwise moment = force ( $T$ )  $\times$  perpendicular distance

The *perpendicular distance* refers to the perpendicular distance between the fulcrum (at X) and the line that the force  $T$  is acting in (referred to as 'the line of the force'). This is indicated by the distance  $d$  in the diagram.

From trigonometry we can see that the distance  $d = 1.2 \sin 35$

$$\begin{aligned} \text{Anti-clockwise moment} &= (T) \times \text{perpendicular distance} \\ &= (T)(1.2 \sin 35) \end{aligned}$$

Total clockwise moment = anti-clockwise moment

$$678 = (T)(1.2 \sin 35)$$

$$T = 985 \text{ N}$$

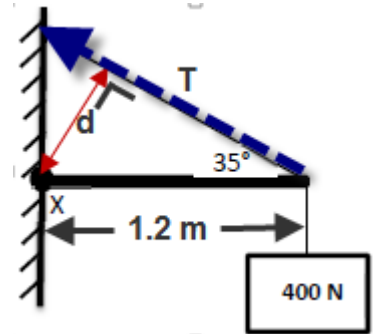

(viii) **A rotating object can be in equilibrium. Explain how this can happen.**

It can be in equilibrium if its angular velocity is constant

### 2011 Question 6

(a)

(i) **Define the moment of a force.**

Moment of a force = force  $\times$  perpendicular distance between the force and the fulcrum

(ii) **When the toy is knocked over, it always returns to the upright position. Explain why this happens.**

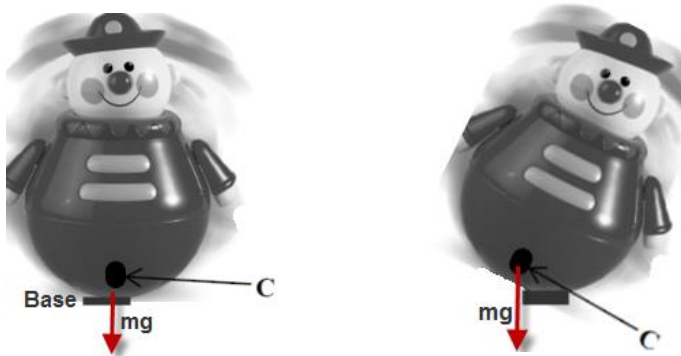

Note that the weight of an object always acts through the centre of gravity (indicated by C in both diagrams).

Note also that in both diagrams the toy is rotating around the base, where the base corresponds to the area of contact between the toy and the ground.

There is no turning effect when the toy is in *upright* position because the line of action of the force (weight) passes through the base, so the perpendicular distance is zero.

However when the toy is in a *non-vertical* position its weight *has* a turning effect because now there is a (small) perpendicular distance between the line of action and the fulcrum (base).

*Good luck explaining all that in an exam.*

(b)

(i) **State the conditions necessary for the equilibrium of a body under a set of co-planar forces.**

Vector sum of the forces = zero

Sum of the clockwise moments about any point = sum of the anti-clockwise moments about that point

(ii) **Where should the third child of mass 45 kg sit, in order to balance the see-saw?**

sum of anti-clockwise moments = sum of clockwise moments

$$30g(1.8) = 40g(0.8) + 45g(x)$$

*Cancel g's:*

$$30(1.8) = 40(0.8) + 45(x)$$

$$54 = 32 + 45(x)$$

$$22 = 45(x)$$

$$x = 0.49 \text{ m}$$

### 2006 Question 12 (a)

(i) **Define pressure.**

Pressure = Force divided by area.

(ii) **Is pressure a vector quantity or a scalar quantity? Justify your answer.**

It is a scalar because it has no direction.

(iii) **State Boyle's law.**

Boyle's Law states that for a fixed mass of gas pressure is inversely proportional to volume if temperature is constant.

(iv) **Calculate the pressure at the bottom of the lake.**

$$P \propto \frac{1}{V}$$

*{So if the volume increases by a factor of 3 (threefold) then the pressure decreases by a factor of 3.*

*So the pressure at the top of the lake is 3 times smaller than the pressure at the bottom of the lake.*

*So the pressure at the bottom of the lake is 3 times greater than the pressure at the top of the lake.}*

Answer: Pressure at bottom =  $3 \times (1.01 \times 10^5) = 3.03 \times 10^5$  Pa

*{Why were you told that the temperature is 4 °C? - presumably just to note that the temperature remained constant}*

(v) **Calculate the depth of the lake.**

$$\Delta P = (\rho)(g)(\Delta h)$$

$$\Delta h = \frac{\Delta P}{(\rho)(g)}$$

$$\text{change in height} = \frac{\text{change in pressure}}{(\rho)(g)}$$

$$\Delta h = \frac{(3.03 \times 10^5) - (1.01 \times 10^5)}{(1.0 \times 10^3)(9.8)}$$

Answer: Depth of lake = 20.61 m