



**Coimisiún na Scrúduithe Stáit
State Examinations Commission**

LEAVING CERTIFICATE EXAMINATION, 2004

PHYSICS – HIGHER LEVEL

MONDAY, 21 JUNE – MORNING 9.30 TO 12.30

Answer **three** questions from **section A** and **five** questions from **section B**.

SECTION A (120 marks)

Answer **three** questions from this section.
Each question carries 40 marks.

1. In an experiment to measure the acceleration due to gravity g by a free fall method, a student measured the time t for an object to fall from rest through a distance s . This procedure was repeated for a series of values of the distance s .

The table shows the data recorded by the student.

s/cm	30	40	50	60	70	80	90
t/ms	244	291	325	342	371	409	420

Describe, with the aid of a diagram, how the student obtained the data. (12)

Calculate a value for the acceleration due to gravity g by drawing a suitable graph based on the recorded data. (21)

Give two precautions that should be taken to ensure a more accurate result. (7)

2. In an experiment to measure the wavelength of monochromatic light, the angle θ between a central bright image ($n = 0$) and the first and second order images to the left and the right was measured. A diffraction grating with 500 lines per mm was used.

The table shows the recorded data.

n	2	1	0	1	2
$\theta/\text{degrees}$	36.2	17.1	0	17.2	36.3

Describe, with the aid of a diagram, how the student obtained the data. (12)

Use all of the data to calculate a value for the wavelength of the light. (15)

Explain how using a diffraction grating with 100 lines per mm leads to a less accurate result. (7)

The values for the angles on the left of the central image are smaller than the corresponding ones on the right. Suggest a possible reason for this. (6)

3. A student investigated the variation of the fundamental frequency f of a stretched string with its length l .

Draw a labelled diagram of the apparatus used in this experiment. Indicate on the diagram the points between which the length of the wire was measured. (12)

The student drew a graph, as shown, using the data recorded in the experiment, to illustrate the relationship between the fundamental frequency of the string and its length.

State this relationship and explain how the graph verifies it. (9)

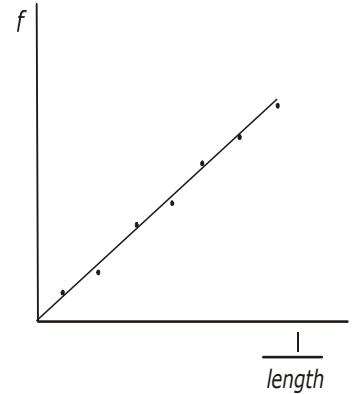

The student **then** investigated the variation of the fundamental frequency f of the stretched string with its tension T . The length was kept constant throughout this investigation.

How was the tension measured? (4)

What relationship did the student discover? (6)

Why was it necessary to keep the length constant? (3)

How did the student know that the string was vibrating at its fundamental frequency? (6)

4. The following is part of a student's report of an experiment to measure the resistivity of nichrome wire.

“The resistance and length of the nichrome wire were found. The diameter of the wire was then measured at several points along its length.”

The following data was recorded.

resistance of wire = 32.1Ω
length of wire = 90.1 cm
diameter of wire = $0.19 \text{ mm}, 0.21 \text{ mm}, 0.20 \text{ mm}, 0.21 \text{ mm}, 0.20 \text{ mm}$

Name an instrument to measure the diameter of the wire and describe how it is used. (12)

Why was the diameter of the wire measured at several points along its length? (6)

Using the data, calculate a value for the resistivity of nichrome. (15)

Give two precautions that should be taken when measuring the length of the wire. (7)

SECTION B (280 marks)

Answer **five** questions from this section.
Each question carries 56 marks.

5. Answer any **eight** of the following parts (a), (b), (c), etc.

- (a) Two forces are applied to a body, as shown. What is the magnitude of the resultant force acting on the body? (7)

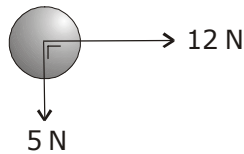

- (b) A can of height 10 cm is submerged in water. What is the difference in pressure between the top and bottom of the can? (7)
(acceleration due to gravity = 9.8 m s^{-2} ;
density of water = 1000 kg m^{-3})

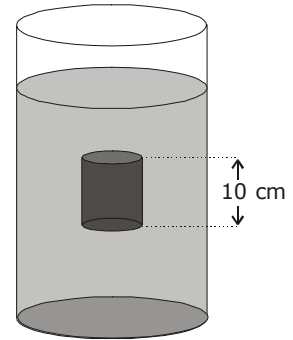

- (c) Explain the term thermometric property. (7)
- (d) The sound intensity doubles as a person approaches a loudspeaker. What is the increase in the sound intensity level? (7)
- (e) Two converging lenses, each with a focal length of 10 cm, are placed in contact. What is the power of the lens combination? (7)
- (f) What is meant by polarisation of waves? (7)
- (g) Identify two hazards caused by static electricity. (7)
- (h) The activity of a radioactive isotope decays to $1/16^{\text{th}}$ of its original value after 36 years. What is the half-life of the isotope? (7)
- (i) Give one use of the earth's magnetic field. (7)
- (j) Give the quark composition of the neutron. (7)
- or**
- List two factors that affect the efficiency of a transformer. (7)

6. Define (i) force, (ii) momentum. (12)

State Newton's second law of motion.

Hence, establish the relationship: force = mass \times acceleration. (15)

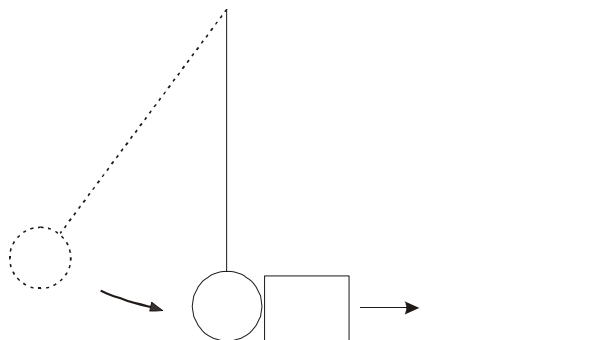

A pendulum bob of mass 10 g was raised to a height of 20 cm and allowed to swing so that it collided with a block of mass 8.0 g at rest on a bench, as shown. The bob stopped on impact and the block subsequently moved along the bench.

Calculate

- (i) the velocity of the bob just before the collision;
(ii) the velocity of the block immediately after the collision. (18)

The block moved 2.0 m along the bench before stopping. What was the average horizontal force exerted on the block while travelling this distance? (11)

(acceleration due to gravity = 9.8 m s^{-2})

7. Define (i) specific heat capacity, (ii) specific latent heat. (12)

500 g of water at a temperature of 15°C is placed in a freezer. The freezer has a power rating of 100 W and is 80% efficient.

- (i) Calculate the energy required to convert the water into ice at a temperature of -20°C .
(ii) How much energy is removed every second from the air in the freezer?
(iii) How long will it take the water to reach a temperature of -20°C ? (27)

Allowing a liquid to evaporate in a closed pipe inside the freezer cools the air in the freezer. The vapour is then pumped through the pipe to the outside of the freezer, where it condenses again. Explain how this process cools the air in the freezer. (12)

The freezer causes the room temperature to rise. Explain why. (5)

(specific heat capacity of ice = $2100 \text{ J kg}^{-1} \text{ K}^{-1}$; specific heat capacity of water = $4200 \text{ J kg}^{-1} \text{ K}^{-1}$;
specific latent heat of fusion of ice = $3.3 \times 10^5 \text{ J kg}^{-1}$)

8. Define (i) potential difference, (ii) capacitance. (12)

Describe an experiment to demonstrate that a capacitor can store energy. (12)

The circuit diagram shows a $50\ \mu\text{F}$ capacitor connected in series with a $47\ \text{k}\Omega$ resistor, a $6\ \text{V}$ battery and a switch. When the switch is closed the capacitor starts to charge and the current flowing at a particular instant in the circuit is $80\ \mu\text{A}$.

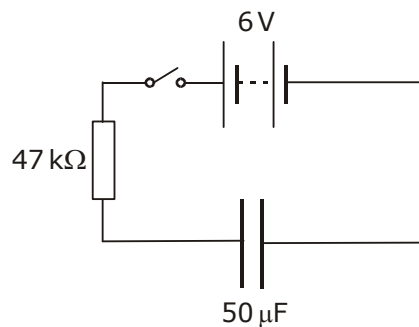

Calculate

- the potential difference across the resistor and hence the potential difference across the capacitor when the current is $80\ \mu\text{A}$;
- the charge on the capacitor at this instant;
- the energy stored in the capacitor when it is fully charged. (27)

Describe what happens in the circuit when the $6\ \text{V}$ d.c. supply is replaced with a $6\ \text{V}$ a.c. supply. (5)

9. Distinguish between photoelectric emission and thermionic emission. (12)

A freshly cleaned piece of zinc metal is placed on the cap of a negatively charged gold leaf electroscope and illuminated with ultraviolet radiation. Explain why the leaves of the electroscope collapse. (9)

Explain why the leaves do **not** collapse when

- the zinc is covered by a piece of ordinary glass;
- the zinc is illuminated with green light;
- the electroscope is charged positively. (15)

The zinc metal is illuminated with ultraviolet light of wavelength $240\ \text{nm}$. The work function of zinc is $4.3\ \text{eV}$.

Calculate

- the threshold frequency of zinc;
- the maximum kinetic energy of an emitted electron. (20)

(Planck's constant = $6.6 \times 10^{-34}\ \text{J s}$; speed of light = $3.0 \times 10^8\ \text{m s}^{-1}$; $1\ \text{eV} = 1.6 \times 10^{-19}\ \text{J}$)

10. Answer **either** part (a) **or** part (b).

- (a) Beta decay is associated with the weak nuclear force.
List two other fundamental forces of nature and give one property of each force. (12)

In beta decay, a neutron decays into a proton with the emission of an electron. Write a nuclear equation for this decay. Calculate the energy released during the decay of a neutron. (21)

Momentum and energy do not appear to be conserved in beta decay. Explain how the existence of the neutrino, which was first named by Enrico Fermi, resolved this. (8)

During the late 1930s, Fermi continued to work on the nucleus. His work led to the creation of the first nuclear fission reactor in Chicago during 1942. The reactor consisted of a 'pile' of graphite moderator, uranium fuel with cadmium control rods.

- (i) What is nuclear fission?
(ii) What is the function of the moderator in the reactor?
(iii) How did the cadmium rods control the rate of fission? (15)

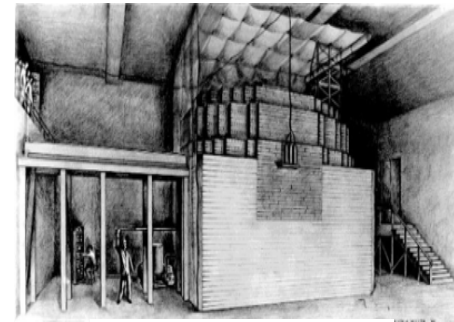

first nuclear reactor

(mass of neutron = 1.6749×10^{-27} kg; mass of proton = 1.6726×10^{-27} kg;
mass of electron = 9.1094×10^{-31} kg; speed of light = 2.9979×10^8 m s⁻¹)

- (b) A current-carrying conductor experiences a force in a magnetic field. Name the factors that affect the magnitude of the force? (9)

Describe a laboratory experiment to demonstrate the principle that a current-carrying conductor in a magnetic field experiences a force. (12)

The operation of a moving coil meter is based on this principle. List two other devices based on this principle. (6)

What is the function of a moving coil galvanometer? Draw a circuit diagram to show how a moving coil galvanometer can be converted into an ammeter. (9)

A moving coil galvanometer has a resistance of 100Ω and a full-scale deflection of 5.00 mA. Calculate the size of the resistor required to convert it into an ammeter with a full-scale deflection of 1.00 A.
What is the effective resistance of the ammeter? (15)

Why does the magnet in a moving coil galvanometer have curved pole faces? (5)

11. Read the following passage and answer the following questions.

Your home is supplied with electricity at 230 volts, 50 Hertz. At the electrical supply intake position is your main consumer unit or fuse board. At that position you will find your main switch. Your sockets, immersion group and bathroom heater (or shower) are protected by Residual Current Devices (RCD) installed in your fuse board. These provide a high degree of safety on these circuits and it is important that they are tested at least every 3 months. The final circuits are protected by Miniature Circuit Breakers (MCB).

It is advisable to contact your local ESB about cheaper night tariffs, these could make significant savings to your electricity bill. Storage heaters may be used to avail of these cheaper rates.

Each plug top contains a small cartridge fuse. Cartridge fuses are supplied with a rating of 1A, 2A, 3A, 5A and 13A. A fuse should never be replaced by anything other than a suitable fuse.

(Adapted from "Home Safety", Register of Electrical Contractors of Ireland. *RECI*)

- (a) Name and give the colour of the wire that should be connected to the fuse in a standard three-pin plug. (7)
- (b) Explain why replacing a fuse with a piece of aluminium foil is dangerous. (7)
- (c) A table lamp has a power rating of 100 W. What is the most suitable fuse for the lamp? (7)
- (d) Some electrical appliances are supplied with two-pin plugs. Why is an earth wire not required in these devices? (7)
- (e) Sketch a voltage-time graph of the 230 V supply. (7)
- (f) Explain how a Residual Current Device (RCD) operates. (7)
- (g) Give one advantage of a Residual Current Device (RCD) over a Miniature Circuit Breaker (MCB). (7)
- (h) Storage heaters have a large heat capacity. Explain why. (7)

12. Answer any **two** of the following parts (a), (b), (c), (d).

(a) State Newton's universal law of gravitation. (6)

Centripetal force is required to keep the earth moving around the sun.

- (i) What provides this centripetal force?
- (ii) In what direction does this centripetal force act?
- (iii) Give an expression for centripetal force. (10)

The earth has a speed of $3.0 \times 10^4 \text{ m s}^{-1}$ as it orbits the sun. The distance between the earth and the sun is $1.5 \times 10^{11} \text{ m}$. Calculate the mass of the sun. (12)

(gravitational constant, $G = 6.7 \times 10^{-11} \text{ m}^3 \text{ kg}^{-1} \text{ s}^{-2}$)

(b) Give two reasons why the telecommunications industry uses optical fibres instead of copper conductors to transmit signals. (6)

Explain how a signal is transmitted along an optical fibre. An optical fibre has an outer less dense layer of glass. What is the role of this layer of glass? (13)

An optical fibre is manufactured using glass of refractive index of 1.5. Calculate the speed of light travelling through the optical fibre. (9)

(speed of light in air = $3.0 \times 10^8 \text{ m s}^{-1}$)

(c) What is electromagnetic induction?
Describe an experiment to demonstrate electromagnetic induction. (15)

A light aluminium ring is suspended from a long thread as shown in the diagram. When a strong magnet is moved away from it, the ring follows the magnet. Explain why.

What would happen if the magnet were moved towards the ring? (13)

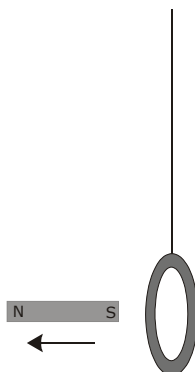

(d) A p-n junction is formed by taking a single crystal of silicon and doping separate but adjacent layers of it. A depletion layer is formed at the junction.

(i) What is doping?

(ii) Explain how a depletion layer is formed at the junction. (15)

The graph shows the variation of current I with potential difference V for a p-n junction in forward bias. Explain, using the graph, how the current varies with the potential difference.

Why does the p-n junction become a good conductor as the potential difference exceeds 0.6 V? (13)

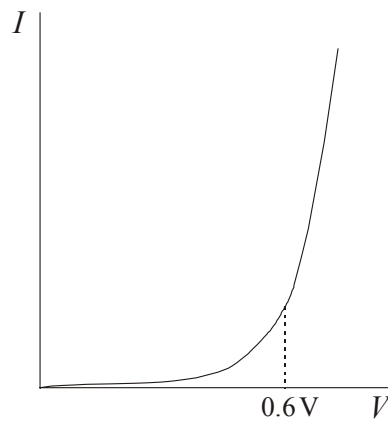

Blank Page

Blank Page