AN ROINN OIDEACHAIS AGUS EOLAÍOCHTA

LEAVING CERTIFICATE EXAMINATION, 2002

PHYSICS – HIGHER LEVEL

MONDAY, 17 JUNE – MORNING 9.30 TO 12.30

Answer **three** questions from **section A** and **five** questions from **section B**.

SECTION A (120 marks)

Answer **three** questions from this section.
Each question carries 40 marks.

1. A student investigated the laws of equilibrium for a set of co-planar forces acting on a metre stick. The weight of the metre stick was 1 N and its centre of gravity was found to be at the 50.5 cm mark. Two spring balances and a number of weights were attached to the metre stick. Their positions were adjusted until the metre stick was in horizontal equilibrium, as indicated in the diagram. The reading on the spring balance attached at the 20 cm mark was 2 N and the reading on the other spring balance was 4 N. The other end of each spring balance was attached to a fixed support.

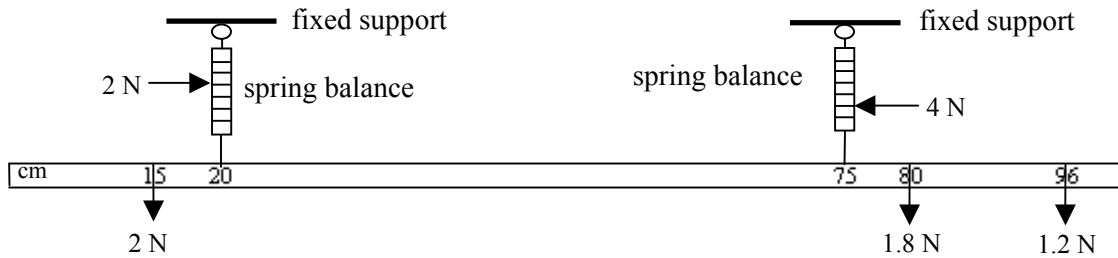

Calculate the sum of the upward forces and the sum of the downward forces acting on the metre stick. Explain how these experimental values verify one of the laws of equilibrium for a set of co-planar forces. (9)

Calculate the sum of the clockwise moments and the sum of the anticlockwise moments about an axis through the 10 cm mark on the metre stick. Explain how these experimental values verify the second law of equilibrium for a set of co-planar forces. (18)

Describe how the centre of gravity of the metre stick was found. (6)

Why was it important to have the spring balances hanging vertically? (7)

2. In an experiment to measure the specific latent heat of fusion of ice, warm water was placed in an aluminium calorimeter. Crushed dried ice was added to the water. The following results were obtained.

Mass of calorimeter	= 77.2 g
Mass of water.....	= 92.5 g
Initial temperature of water	= 29.4 °C
Temperature of ice	= 0 °C
Mass of ice.....	= 19.2 g
Final temperature of water.....	= 13.2 °C

Room temperature was 21 °C. What was the advantage of having the room temperature approximately halfway between the initial temperature of the water and the final temperature of the water? (9)

Describe how the mass of the ice was found. (9)

Calculate a value for the specific latent heat of fusion of ice. The specific heat capacity of aluminium is 790 J kg⁻¹ K⁻¹ and the specific heat capacity of water is 4180 J kg⁻¹ K⁻¹. (15)

The accepted value for the specific latent heat of fusion of ice is 3.3 × 10⁵ J kg⁻¹, suggest two reasons why your answer is not this value. (7)

3. A student obtained the following data during an investigation of the variation of the fundamental frequency f of a stretched string with its tension T . The length of the string was kept constant.

T/N	15	20	25	30	35	40	45
f/Hz	264	304	342	371	402	431	456

Describe, with the aid of a diagram, how the student obtained the data. (12)

Why was the length of the string kept constant during the investigation? (6)

Plot a suitable graph on graph paper to show the relationship between fundamental frequency and tension for the stretched string. (15)

From your graph, estimate the tension in the string when its fundamental frequency is 380 Hz. (7)

4. In an experiment to investigate the variation of current I with potential difference V for a copper sulfate solution, the following results were obtained.

V/V	0.5	1.0	1.5	2.0	2.5	3.0	3.5	4.0	4.5	5.0
I/mA	24	48	79	102	120	143	185	195	215	263

Draw a diagram of the apparatus used in this experiment, identifying the anode and the cathode. (12)

Draw a suitable graph on graph paper to show how the current varies with the potential difference. (12)

Using your graph, calculate the resistance of the copper sulfate solution. (Assume the resistance of the electrodes is negligible.) (9)

Draw a sketch of the graph that would be obtained if inactive electrodes were used in this experiment. (7)

SECTION B (280 marks)

Answer **five** questions from this section.
Each question carries 56 marks.

5. Answer any **eight** of the following parts (a), (b), (c), etc.

- (a) A particle travels at a constant speed of 10 m s^{-1} in a circle of radius 2 m. What is its angular velocity? (7)
- (b) Give the equation that defines temperature on the Celsius scale. (7)
- (c) The solar constant is 1.35 kW m^{-2} . What is the average amount of energy falling normally on each square metre of the earth's atmosphere in one year? (one year = $3.16 \times 10^7 \text{ s}$) (7)
- (d) What is the Doppler effect? (7)
- (e) Define sound intensity. (7)
- (f) A diffraction grating has 200 lines per mm. What is the value of d in the diffraction grating formula $n\lambda = d \sin \theta$? (7)
- (g) How much energy is stored in a $100 \mu\text{F}$ capacitor when it is charged to a potential difference of 12 V? (7)
- (h) What is the purpose of a residual current device (RCD) in an electrical circuit? (7)
- (i) A current-carrying conductor experiences a force when placed in a magnetic field. Name two factors that affect the magnitude of the force. (7)
- (j) What is meant by nuclear fission? (7)

6. State Newton's second law of motion. (6)

The equation $F = -ks$, where k is a constant, is an expression for a law that governs the motion of a body.

Name this law and give a statement of it. (9)

Give the name for this type of motion and describe the motion. (9)

A mass at the end of a spring is an example of a system that obeys this law. Give two other examples of systems that obey this law. (6)

The springs of a mountain bike are compressed vertically by 5 mm when a cyclist of mass 60 kg sits on it. When the cyclist rides the bike over a bump on a track, the frame of the bike and the cyclist oscillate up and down.

Using the formula $F = -ks$, calculate the value of k , the constant for the springs of the bike. (6)

The total mass of the frame of the bike and the cyclist is 80 kg. Calculate (i) the period of oscillation of the cyclist, (ii) the number of oscillations of the cyclist per second. (20)



(acceleration due to gravity, $g = 9.8 \text{ m s}^{-2}$)

7. “Constructive interference and destructive interference take place when waves from two coherent sources meet.”

Explain the underlined terms in the above statement. (12)

What is the condition necessary for destructive interference to take place when waves from two coherent sources meet? (6)

Describe an experiment that demonstrates the wave nature of light. (12)

Radio waves of frequency 30 kHz are received at a location 1500 km from a transmitter. The radio reception temporarily “fades” due to destructive interference between the waves travelling parallel to the ground and the waves reflected from a layer (ionosphere) of the earth’s atmosphere, as indicated in the diagram.

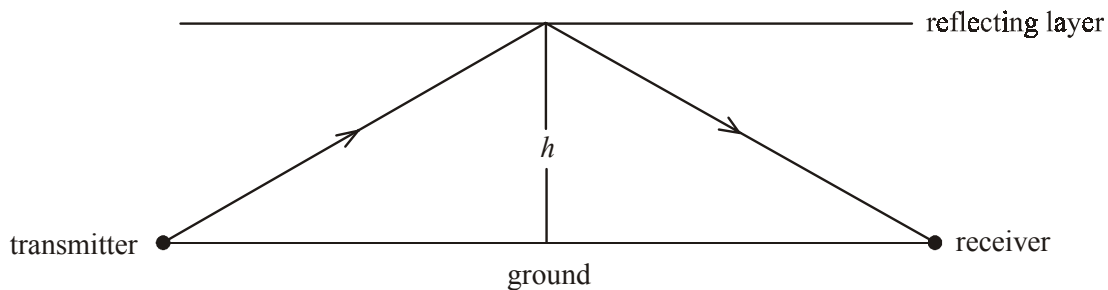

(i) Calculate the wavelength of the radio waves. (6)

(ii) What is the minimum distance that the reflected waves should travel for destructive interference to occur at the receiver? (9)

(iii) The layer at which the waves are reflected is at a height h above the ground. Calculate the minimum height of this layer for destructive interference to occur at the receiver. (11)

(speed of light, $c = 3.0 \times 10^8 \text{ m s}^{-1}$)

8. Define (i) power, (ii) resistivity. (12)

Describe an experiment that demonstrates the heating effect of an electric current. (12)

The ESB supplies electrical energy at a rate of 2 MW to an industrial park from a local power station, whose output voltage is 10 kV. The total length of the cables connecting the industrial park to the power station is 15 km. The cables have a diameter of 10 mm and are made from a material of resistivity $5.0 \times 10^{-8} \Omega \text{ m}$.

Calculate

(i) the total resistance of the cables; (15)

(ii) the current flowing in the cables; (6)

(iii) the rate at which energy is “lost” in the cables. (6)

Suggest a method of reducing the energy “lost” in the cables. (5)

9. Explain with the aid of a labelled diagram how X-rays are produced. (15)

Justify the statement “X-ray production may be considered as the inverse of the photoelectric effect.” (9)

Describe an experiment to demonstrate the photoelectric effect. (12)

Outline Einstein’s explanation of the photoelectric effect. (15)

Give two applications of a photocell. (5)

10. Answer either part (a) or part (b)

(a) Name the four fundamental forces of nature. (12)

Which force is responsible for binding the nucleus of an atom? Give two properties of this force. (9)

In 1932, Cockcroft and Walton carried out an experiment in which they used high-energy protons to split a lithium nucleus. Outline this experiment. (11)

When a lithium nucleus (${}^7_3\text{Li}$) is bombarded with a high-energy proton, two α -particles are produced.

Write a nuclear equation to represent this reaction. (12)

Calculate the energy released in this reaction. (12)

(mass of proton = 1.6730×10^{-27} kg; mass of lithium nucleus = 1.1646×10^{-26} kg;
mass of α -particle = 6.6443×10^{-27} kg; speed of light, $c = 3.00 \times 10^8$ m s $^{-1}$)

(b) What is a semiconductor? (6)

Explain why the resistance of a semiconductor changes with temperature. (9)

Sketch a graph showing the relationship between resistance and temperature for a semiconductor. (6)

Draw a labelled diagram showing the basic structure of a bipolar transistor. (9)

The circuit diagram shows a transistor being used as a simple voltage amplifier.

Explain how the circuit operates. (12)

Sketch graphs of the input and output voltages, using the same axes and scale. (9)

Give another use for a transistor. (5)

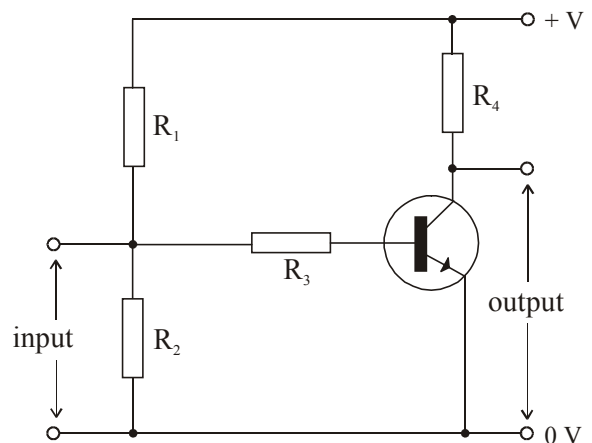

11. Read the following passage and answer the accompanying questions.

Benjamin Franklin designed the lightning conductor. This is a thick copper strip running up the outside of a tall building. The upper end of the strip terminates in one or more sharp spikes above the highest point of the building. The lower end is connected to a metal plate buried in moist earth. The lightning conductor protects a building from being damaged by lightning in a number of ways.

During a thunderstorm, the value of the electric field strength in the air can be very high near a pointed lightning conductor. If the value is high enough, ions, which are drawn towards the conductor, will receive such large accelerations that, by collision with air molecules, they will produce vast additional numbers of ions. Therefore the air is made much more conducting and this facilitates a flow of current between the air and the ground. Thus, charged clouds become neutralised and lightning strikes are prevented. Alternatively, in the event of the cloud suddenly discharging, the lightning strike will be conducted through the copper strip, thus protecting the building from possible catastrophic consequences.

Raised umbrellas and golf clubs are not to be recommended during thunderstorms for obvious reasons.

On high voltage electrical equipment, pointed or roughly-cut surfaces should be avoided.

(Adapted from “Physics – a teacher’s handbook”, Dept. of Education and Science.)

- (a) Why is a lightning conductor made of copper? (7)
- (b) What is meant by electric field strength? (7)
- (c) Why do the ions near the lightning conductor accelerate? (7)
- (d) How does the presence of ions in the air cause the air to be more conducting? (7)
- (e) How do the charged clouds become neutralised? (7)
- (f) What are the two ways in which a lightning conductor prevents a building from being damaged by lightning? (7)
- (g) Why are raised umbrellas and golf clubs not recommended during thunderstorms? (7)
- (h) Explain why pointed surfaces should be avoided when using high voltage electrical equipment. (7)

12. Answer any **two** of the following parts (a), (b), (c), (d).

- (a) State the principle of conservation of momentum. (6)

A spacecraft of mass 50 000 kg is approaching a space station at a constant speed of 2 m s^{-1} . The spacecraft must slow to a speed of 0.5 m s^{-1} for it to lock onto the space station.

Calculate the mass of gas that the spacecraft must expel at a speed 50 m s^{-1} for the spacecraft to lock onto the space station. (The change in mass of the spacecraft may be ignored.) (12)

In what direction should the gas be expelled? (4)

Explain how the principle of conservation of momentum is applied to changing the direction in which a spacecraft is travelling. (6)

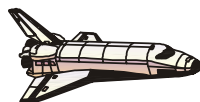

spacecraft

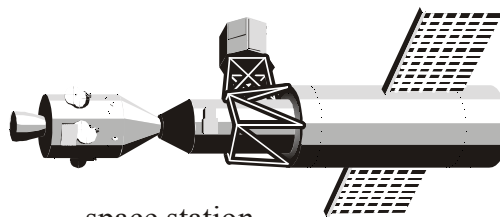

space station

(b) State the laws of refraction of light. (6)

Draw a labelled diagram showing the optical structure of the eye. (9)

How does the eye bring objects at different distances into focus? (6)

The power of a normal eye is $+60 \text{ m}^{-1}$. A short-sighted person's eye has a power of $+65 \text{ m}^{-1}$. Calculate (i) the power, (ii) the focal length, of the contact lens required to correct the person's short-sightedness. (7)

(c) What is meant by electromagnetic induction? (6)

State Lenz's law of electromagnetic induction. (6)

In an experiment, a coil was connected in series with an ammeter and an a.c. power supply as shown in the diagram. Explain why the current was reduced when an iron core was inserted in the coil. (12)

Give an application of the principle shown by this experiment. (4)

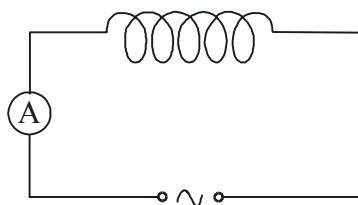

(d) The diagram shows a simplified arrangement of an experiment carried out early in the 20th century to investigate the structure of the atom.

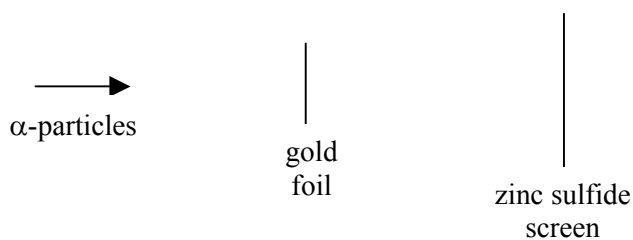

Name the scientist who carried out this experiment. (4)

Describe what was observed in this experiment. (9)

Why was it necessary to carry out this experiment in a vacuum? (6)

What conclusion did the scientist form about the structure of the atom? (9)